



The joy of washing bottles

erich **baumgartner** **tec**hnik - industrial rinsing

General importer for



Industrial washing machines

Product information bottle washing machines



Inventor of the bottle washing machine with the smart bottle basket

suitable for all bottles from 0.1 l to 2.0 l (or bottle height of 400 mm), beer barrels of up to 30 litres in EURO or DIN standard as well as beverage crates.



Equipped with a bottle basket as well as a crate carrier insert as standard.



The washing and rinsing system which was specially developed for the cleaning of bottles, guarantees that all kinds of bottles (beer bottles, milk bottles, juice bottles, water bottles, yoghurt jars and much more) are washed germ-free inside and outside.

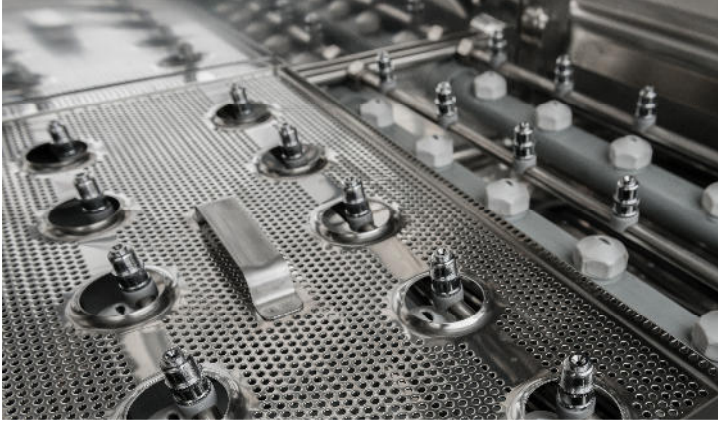

2 separate rinsing processes (washing and rinsing) guarantee hygiene at highest level also for small quantities of wash items.

Efficient and cost efficient.

The strainer makes sure that detached labels from the bottles do not enter into the detergent solution.

The washing program takes 6 minutes and 30 seconds. In a washing cycle of 6 minutes barely 2000 litres of detergent solution are circulated in the system. Depending on the type of bottle up to 54% of the circulation rate are flushed in the bottle and the remainder is flushed outside around the bottle. During the rinsing cycle about 8.7 l of fresh water are flushed in and around the bottles.

Functional principle:

The fresh water is controlled with a magnetic valve and conveyed into the washing chamber. Supported by a built-in booster pump the fresh water is sprayed into the washing chamber with the bottom rinsing nozzles.

At the same time chemicals for the detergent solution are conveyed into the washing chamber.

There are 2 heaters with a power of 4.5 kW each in the washing chamber. As soon as a filling level in the tank has been attained, the magnetic valve will switch on and the heater will start heating the water to about 57°C. If there is too little current available to the customer it would be possible to disconnect the heater. This would ensure that there will be waiting times between the individual washing cycles. A control lamp shows that the desired temperature has been attained.

By pressing the start button the detergent solution (29 l) in the tank will be circulated in the washing chamber. The washing pump conveys 330 l /min. of detergent solution in the washing chamber and cleans the bottles inside and outside.

In each washing cycle a quantity of fresh water of about 8.7 l is rinsed in and around the bottles by means of special nozzles. This way, the detergent solution is rinsed from the inside of the bottles and also required chemicals are conveyed into the tank in order to guarantee another hygienic cleaning.

After the washing cycle the machine will automatically heat the detergent solution to the pre-set washing temperature. A control lamp shows that the machine is ready-for-operation and another washing cycle can be performed.

The chemicals which are specially produced for our bottle washing machine can be used as liquid detergent to clean beer bottles or as enzyme powder to clean milk bottles and yoghurt jars.

The customer is free to use any other chemicals besides the one recommended by us. However, in this case we cannot be held liable for the sterility of the bottles or for the complete rinsing out of the detergent solution.

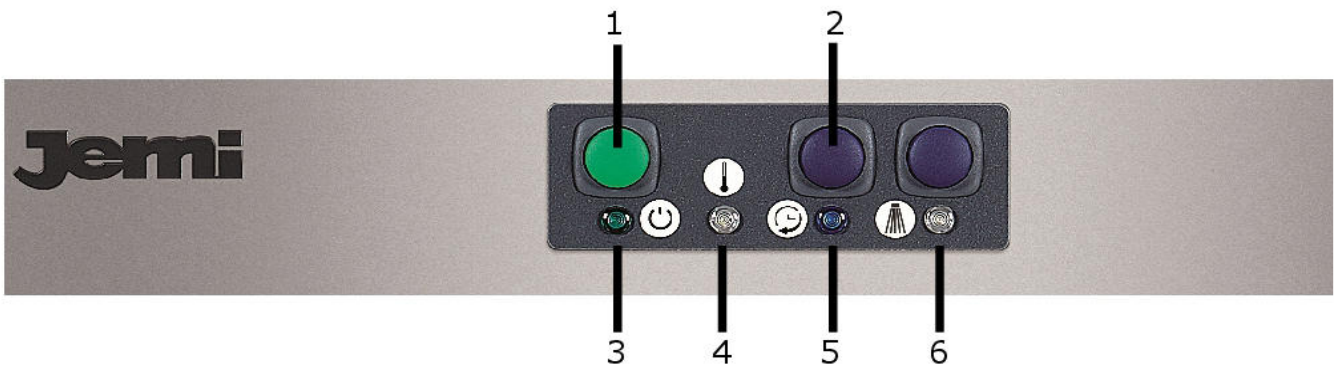

The new operating panel allows an easy and safe operation of the machine.

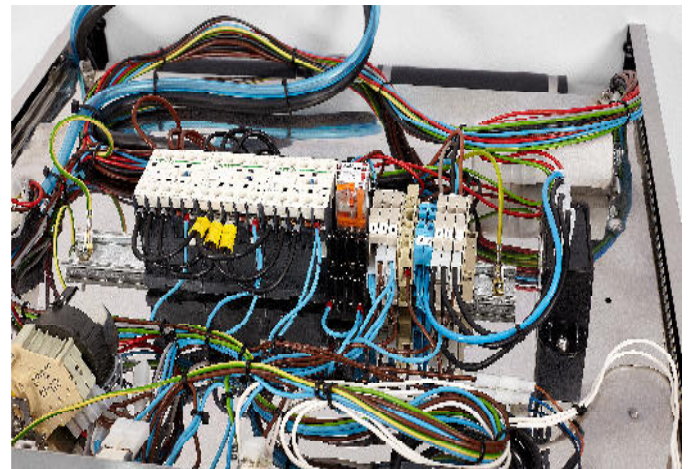
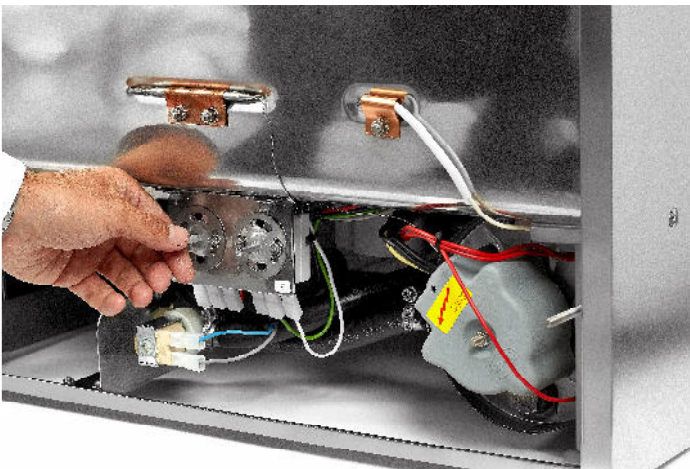

The whole technology of the bottle washing machine is electromechanical. No electronics or boards included. Therefore, the machine is easy to operate and a rapid troubleshooting is guaranteed.

An automatic dosing for the liquid detergent is installed as a standard.

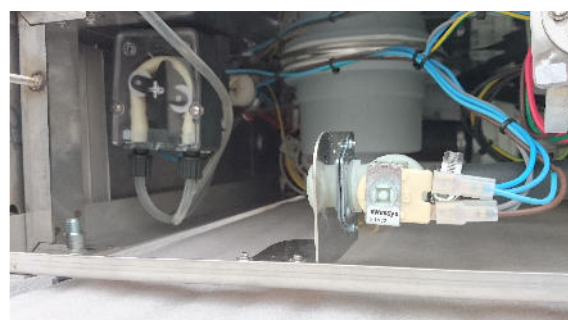



The new booster pump guarantees optimum fresh water rinsing after the washing cycle.

The recirculating pump for the detergent solution has a circulation rate of 330 l /min.

With our new modular system and the template included in the delivery, it is possible to exactly position almost any kind of bottles in the bottle basket and perfectly clean them from the inside and outside in the bottle washing machine.



In this way, you are not bound to any bottle type and you can rapidly convert e.g. From long-neck bottles to flip top or NRW bottles. Or from 0.5 l milk bottles, e.g. to 1.0 l milk bottles.

The new basket system – as individual as the product of our customers.

By using the conversion KIT for barrel cleaning, it would be possible to convert the bottle washing machine to a barrel cleaning machine within a few minutes.

Rapidly and cost-efficient just as the whole bottle washing machine.



Customer responses – please find other responses on www.flaschenwaschen.com

Dear Mr. Baumgartner,

I am completely satisfied with the bottle washing machine made by the company Ebatec. The machine is perfect for the quantity of bottles used by us. The result of the cleaning is convincing and the installation as well as the operation are really easy to handle. The contact with the company Ebatec and the service were and are very good.

With best regards from the airport Munich

René Jacobsen
Graduated master brewer

René Jacobsen
Divisions restaurants - Municon - Catering
Head of department brewery

**Allresto Flughafen München
Hotel und Gaststätten GmbH**
Terminalstraße Mitte 18
D-85356 München-Flughafen

Phone +49 89 975 931 15
Fax +49 89 975 931 18
Mobile +49 174 909 51 13
rene.jacobsen@munich-airport.de
www.munich-airport.de

The new brand positioning of the airport Munich. Experience more under <http://www.verbindung-leben.de>



Hallo Erich,
Please find my comment as follows:

the new bottle washing machine is an enormous relief. It works reliably and clean. I could no longer imagine a life without it.

Warm greetings
Rudi



Privatbrauerei Rudolf Malle | Hochpirkachweg 3 | 9500 Villach | Telefon +43 660 7624040
braumeister@mallebier.at | www.mallebier.at | UID-Nummer: ATU56061807

Dear Mr. Baumgartner, Dear Erich!

Our bottle washing machine has been operated for sometime now and is working perfectly.
The bottles are clean and this way I have no doubts to refill them with milk and deliver the milk to our customers.
Thank you very much for the good cooperation

Kind regards

Buachberger's Mill
Fam. Aigner
Buchberg 1
5163 Mattsee
0664 53 06 641
Mail: info@buchbergmilch.at
Web: www.buchbergmilch.at

Lieber Erich

Dear Erich,
Dear Martin,

I would herewith like to thank you for your brilliant bottle washing machine.
After looking for a long time for an easy yet best possible way to clean the bottles in our tavern brewery-I have finally found you.

In February 2016 I picked up the GS21 at your premises only two weeks after having placed my order. Since that day I am absolutely happy and satisfied by our work.

The installation at the site in Kaltental was very easy and in just 20 minutes the machine was already operating. The consumption of detergent is very economic and this with best washing results. Also the final cleaning after the washing cycle could not be any easier.

All in all -a very thoroughly thought project. My compliments

Happy bottle cleaning!

Dominik Schempp
Master brewer

Important installation instructions: The water outlet should not be higher than 60 mm from the machine base.
Water supply: 2.5 bar permanent flow pressure, connection 3/4" (no Gardena hose) Power requirement: 10 kW
400 volts

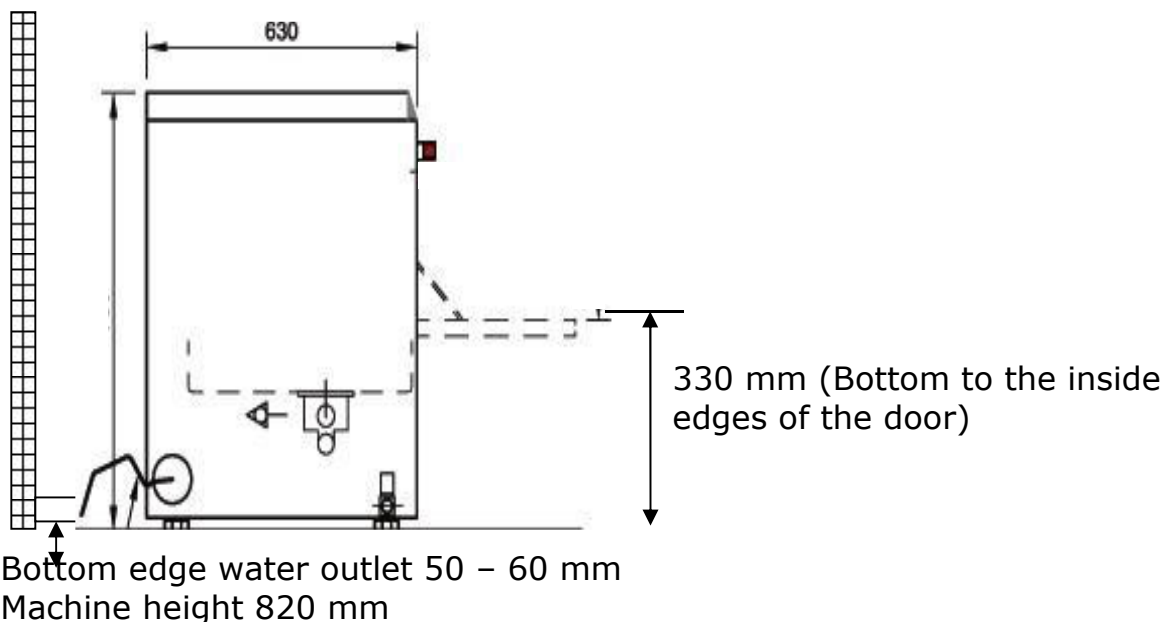

Technical data:

WEEE-Reg.No.:	DE 51131709
Hourly output	about 190 bottles/h
Rinsing time:	6 min 30 sec.
Pump capacity:	736 W
Circulation rate:	330 l. / min.
Tank heater:	2 x 4500 W
Overall connected load:	9736 W
Voltage:	400 volts
Tank contents:	29 l.
Water consumption/rinsing cycle:	about 8.7 l
Required permanent flow pressure:	2.5 bars
Connection/Supply and drain	3/4" 50 mm Ø
Rack height:	Bottles of up to 400 mm
Basket dimensions:	500 x 500 mm
Equipment of baskets:	1 bottle basket
	1 crate carrier for beer crates
Dimensions:	
Width:	580 mm
Depth:	650 mm
Height incl. feet:	820 mm

Example of cost calculation for 10 washing cycles = 200 bottles:

Water consumption:		
Filling of 29 l + 10 washing cycles of 8.7 l = 116 l	= €	0,428
Power consumption:		
At a supply temperature of +6°C about 7 kWh current	= €	1,750
Consumption of chemicals:		
Factory setting 2.2g/l Fresh water = 255 g	= €	1,445

Thus the cleaning of 200 bottles will cost about € 0,0181 per bottle.

Net prices plus VAT:

Beer bottle washing machine GS 21 incl.: 1 bottle basket, 1 crate carrier, dosing pump, strainer, booster pump, template and small items for the construction of the basket. The water inlet, water outlet, power connection and chemical hose are pre-assembled.

Complete price €	2.960,--
Bottle basket extra €	320,--
Conversion kit for barrel cleaning €	480,--
Beer bottle cleaning chemicals 6 kg package €	34,--
Transportation costs within Austria €	100,--
Transportation costs to Germany €	130,--

The prices are subject to change. The General Terms and Conditions of the company Erich Baumgartner A-5222 Munderfing are applicable.

www.facebook.com/flaschenwaschen
www.flaschenwaschen.com