



Freude am Spülen

erich baumgartner technik - gewerbliche Spülsysteme

Generalimporteur für



Gewerbliche

Spülmaschinen

# Operating Instructions Beer Bottle Rinsing Machine GS 21

September 2016

Erich Baumgartner  
Gastronomiemaschinengroßhandel  
Hauptstrasse 4  
A - 5222 Munderfing  
Tel.: 0043 / 7744 / 20 12 10  
Fax: 0043 / 7744 / 20 12 12  
E-mail: [verkauf@gastrohandel.at](mailto:verkauf@gastrohandel.at)

Installation, First commissioning	Page	2,3
Rinsing	Page	4
Emptying the machine, Internal cleaning	Page	5,6
Possible Troubleshooting	Page	7
Wiring diagram	Page	8 - 10
Technical data	Page	11
Bottle basket (Assembly)	Page	12 - 15
Important tip for rinsing	Page	16

**Please read the whole Operating Instructions  
before using the machine!!!!**

## Installation and Connection of the Machine

The machine is equipped with the following accessories:

- Power supply 5 x 4 mm<sup>2</sup> connected to the an rinsing machine,
- Supply hose with the fitting connecting pieces and seals,
- Drain hose, 1 bottle carrier basket, 1 carrier for crates

The following conditions described on the installation plan are necessary:

- The water drain at ground level.
- Fresh water tap of the machine at a 3/4" external thread.
- Three-phase power connection with components for current protection (magnetic-thermal and differential). The main switch to be installed (omnipolar section) should have a clearance between the contacts equal or hither than 3 mm.

**The machine can be levelled by means of the height-adjustable feet.**

**It has to be necessary to slightly open and close the door.**

**Remove the white protective film from the machine.**

Remove the front panel below the door.

Connect the water inlet hose at the external thread of the local water tap and the other end to the inlet valve of the water tab at the front part of the machine.

To do so, conduct the supply hose through the rear openings towards the front.

Connect the drain hose to the main drainpipe of the machine as well as to the drain of the installation site.

If necessary cut the rest of the drain hose to size.

The machine has to be connected to a mains voltage of **400 volts 50 Hz**.

### Attention:

**The installations need to be performed by a licensed technician!!**

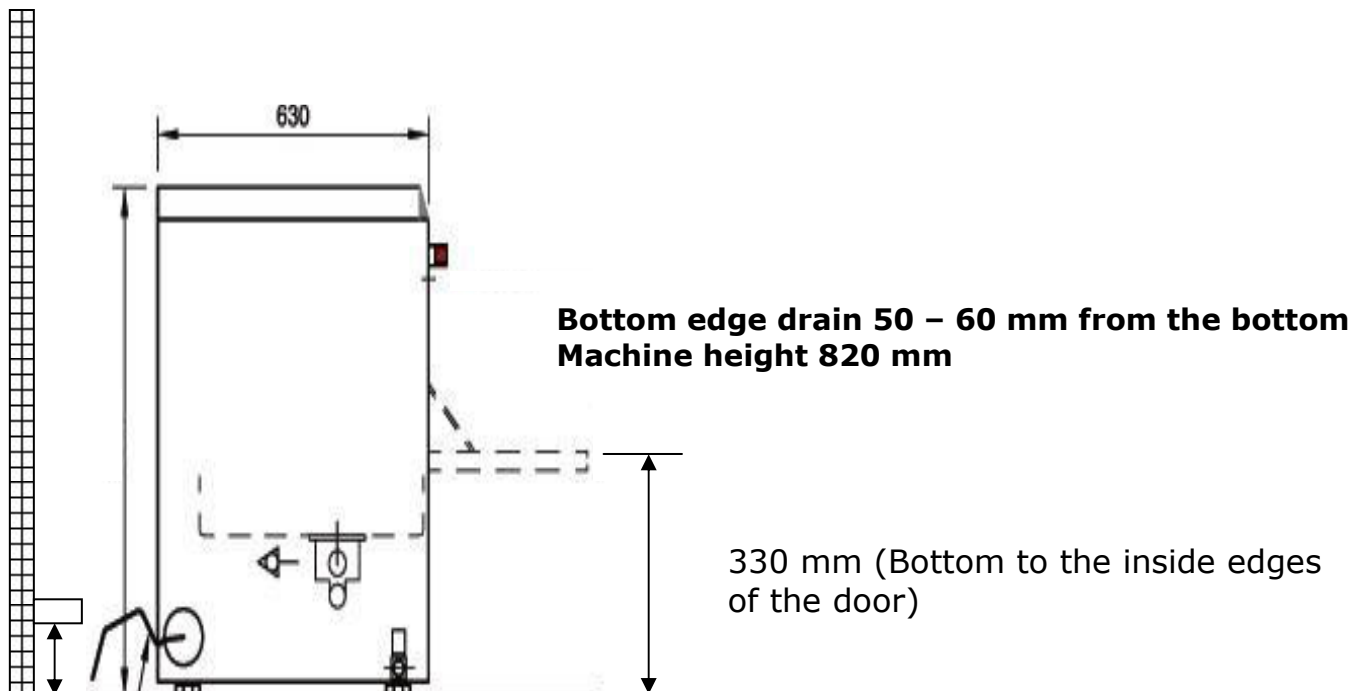

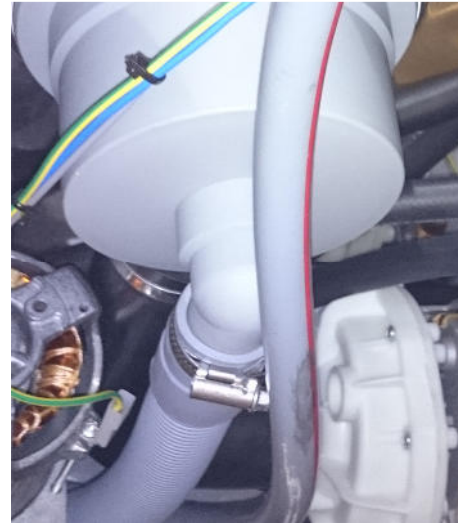
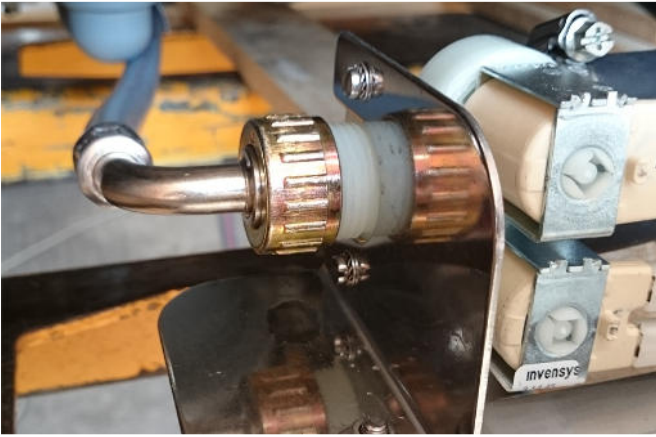

Firstly, manually tighten the nut of the supply hose then by using a pipe wrench.

Do not over tighten the hose clamp of the drain hose.

Take the container with chemicals, drill a hole of about 8 mm Ø into the lid. Insert the hose through the lid and fix the weight and the suction filter.

### First Commissioning

Pull the overflow pipe out of the filter. Switch on the machine by turning the main switch (1).



The machine is being filled with water and chemicals. Wait until the chemicals are filled in the hose.

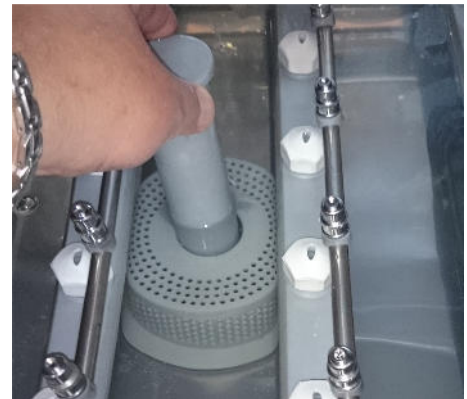

**ATTENTION: THERE IS A RISK OF CHEMICAL BURNS WHEN USING CHEMICALS, ALWAYS WEAR PROTECTIVE GOOGLES AND GLOVES!**

As soon as the chemicals are visible in the hose, switch off the machine.

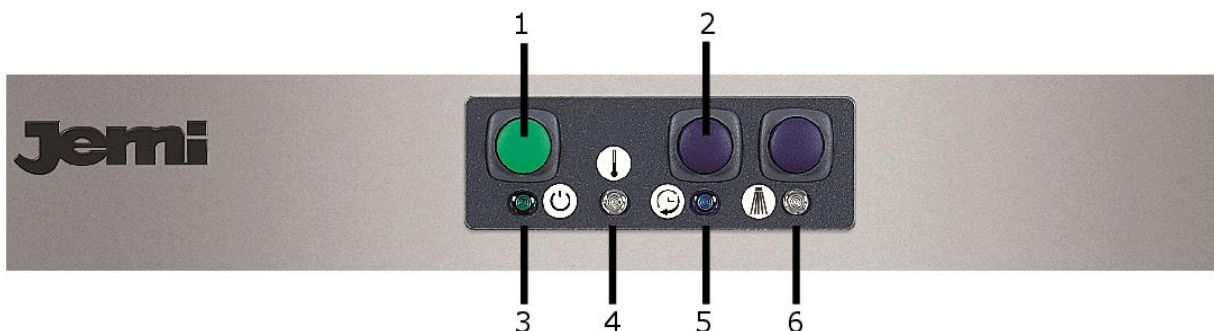

## Rinsing

Check if the suction filter is in the provided position.  
Insert the overflow pipe into the drain.  
Place the surface filter into the machine  
(first remove the protective film).

Close the door and press the mains switch (1)  
**The green indicator light (3) is illuminated.**

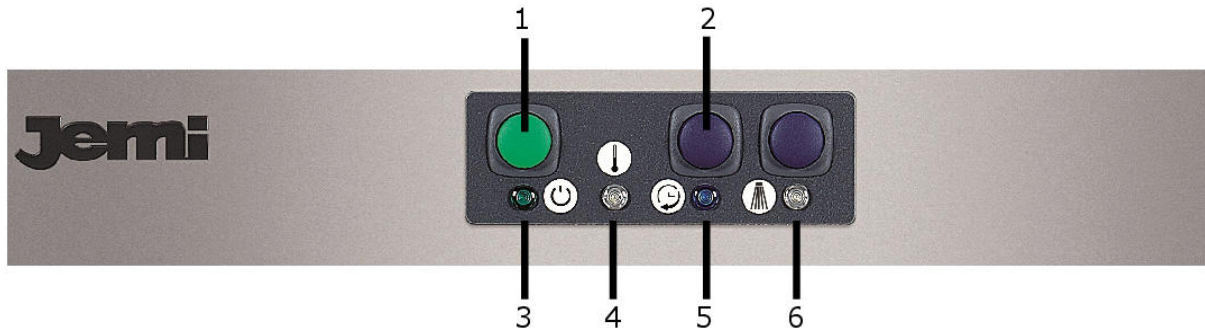
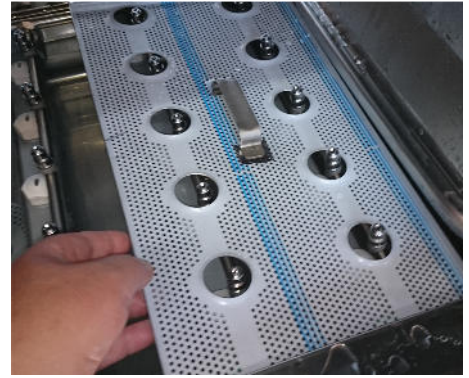

The **automatic filling** of the tank is performed via the inlet valve, the pressure increase pump and via the rinsing system. As soon as the machine attained the water level, the machine will automatically close the water inlet by means of a pressure control device. The pressure control device is set serially with an electro valve which is responsible for filling the machine. At the last position, the tank is being heated up.

The machine is ready for the rinsing process as soon as the correct temperature is attained in the tank (about 57°C).

**The temperature display (4) is illuminated.**

The time required to fill and heat the tank amounts to about 12 to 14 minutes.

### Rinsing agent (Cleaning agent)

For the automatic dosing of the liquid beer bottle cleaning agent the machine is equipped with a cleaning agent dosing device.

### Opening the door and inserting the basket or carrier for crates

Press the start button (2) for the rinsing process. The indicator lamp of the rinsing process (5) is illuminated, the different stages of the rinsing process follow one another: **Rinsing, Dosing of the Cleaning Chemicals, Re-rinsing.**

When the rinsing process is completed (6 min. 30 sec.), the control lamp (5) is switched off and the machine can be used for another rinsing process, as soon as the control lamp (4) is illuminated again.

Depending on the soiling of the bottles or crates, the machine can reuse the same soapy water. If the soapy water is soiled too much, it is necessary to replace the soapy water.

**By pressing the continuous rinsing button (6) it is possible to perform a basic cleaning of the soiled bottles.**

**By repeatedly pressing the button, the rinsing program will be switched off. The machine must not be left unattended during operation.**

## Emptying the Machine

Press the **mains switch (1)**. The control lamp is switched off. Open the door, take out the basket with the clean beer bottles or crates (if there is a basket in the machine), pull out the **overflow pipe** the rinse water will automatically drain out of the tank.

Make sure that the water drains uniformly and rapidly out of the tank.

After finishing work, the machine must be drained. Do not leave soapy water longer in the machine as necessary.

## ATTENTION

THE WATER TEMPERATURE IN THE TANK MAY BE ABOVE 53° C, THERE IS A RISK OF SLIGHT BURNS.

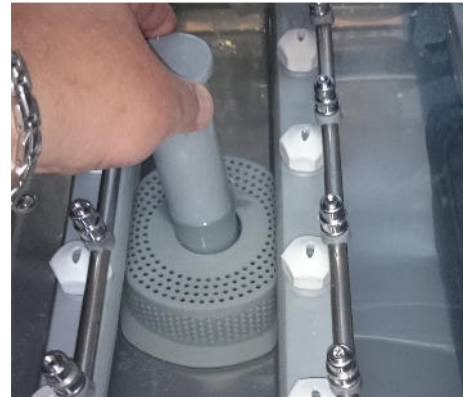

## Interior Cleaning

If the interior of the machine is soiled, it should be **cleaned**.

Remove the surface filters and remove the labels and soiling.



Remove the suction filter and clean it, if required.

Remove the rinsing arms by slightly turning them to the left and slightly pull them out of the bayonet insertion.

Clean soiled nozzles. If you screw off the nozzles, imperatively reinsert them in the same position.

Always make sure that all components in the machine are easy to handle.

Do not apply any force, otherwise parts might break or get damaged.

You may easily clean the interior of the machine. Close the doors, switch on the machine by pressing the mains switch and wait for about 20 sec. The fresh water sprays into the interior.

**(It is necessary to take out the overflow pipe)**



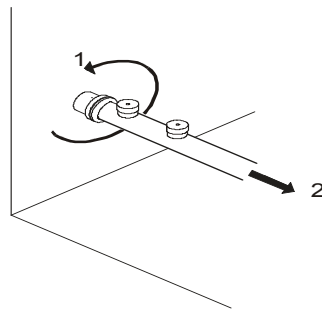
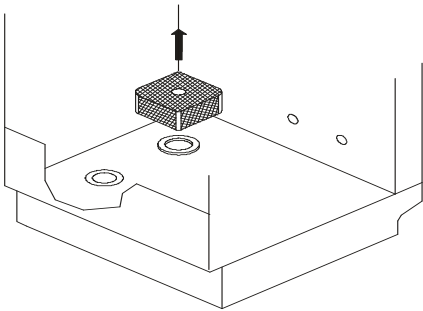
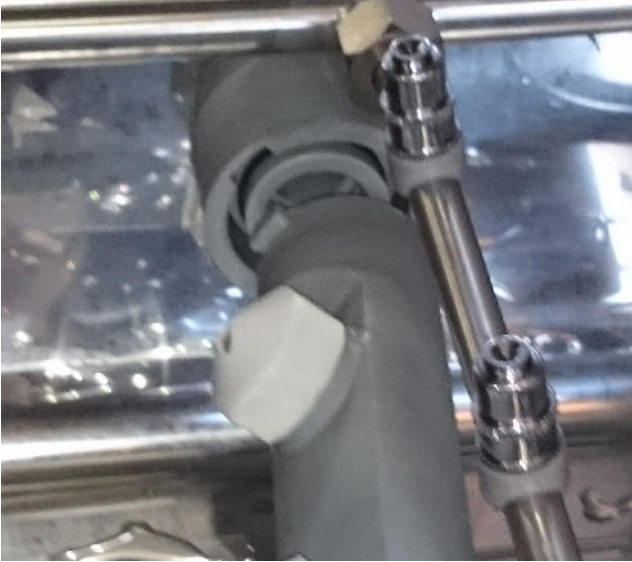

Take off the pump filter and the surface filter and rinse them under flowing water. Take out the rinsing arms by slightly turning them to the left.

To perform the cleaning, it is recommended to place the beer crates on the crate carrier included in the delivery.

The beer crates should be cleaned at the end of the bottle rinsing process. If the soapy water is very soiled, replace it first (refer to Draining the Machine).



After having completed the rinsing process and the cleaning, the door of the machine should be left open.

Insert the overflow pipe into the door frame, so that the interior may "air".

## Possible Troubleshooting

### Malfunction

### Possible cause / Remedy

It is not possible to switch on the machine

The power supply to the machine is interrupted,  
Cause within the machine,  
**Contact the after-sales service**

The machine is not being filled with water

The check valve provided by the customer is closed,  
The air trap is soiled – The level switch does not work,  
The inlet valve is soiled or defective,  
**Contact the after-sales service**

The machine is being filled with water and heats up, but the rinsing program cannot be started

The door contact switch is not in contact/defective,  
The fine wire fuse is blown,  
**Contact the after-sales service**

The machine is continuously filled with water

The overflow pipe is not correctly inserted,

The bottles are not clean

The rinsing temperature is too low,  
Cleaning agent forgotten,  
The machine does not convey the cleaning agent,  
The rinsing agent container is empty,  
The jet nozzles are plugged

The exterior of the machine should only be wiped with a damp cloth.  
Please observe that life switches and control lamps are in the area of the operating panel.

# ELEKTRISCHE SCHALTPLAN GS-21 OHNE BOILER 230V. III / 400V.

AB DER MASCHINE N° ---,---  
BETRIEB

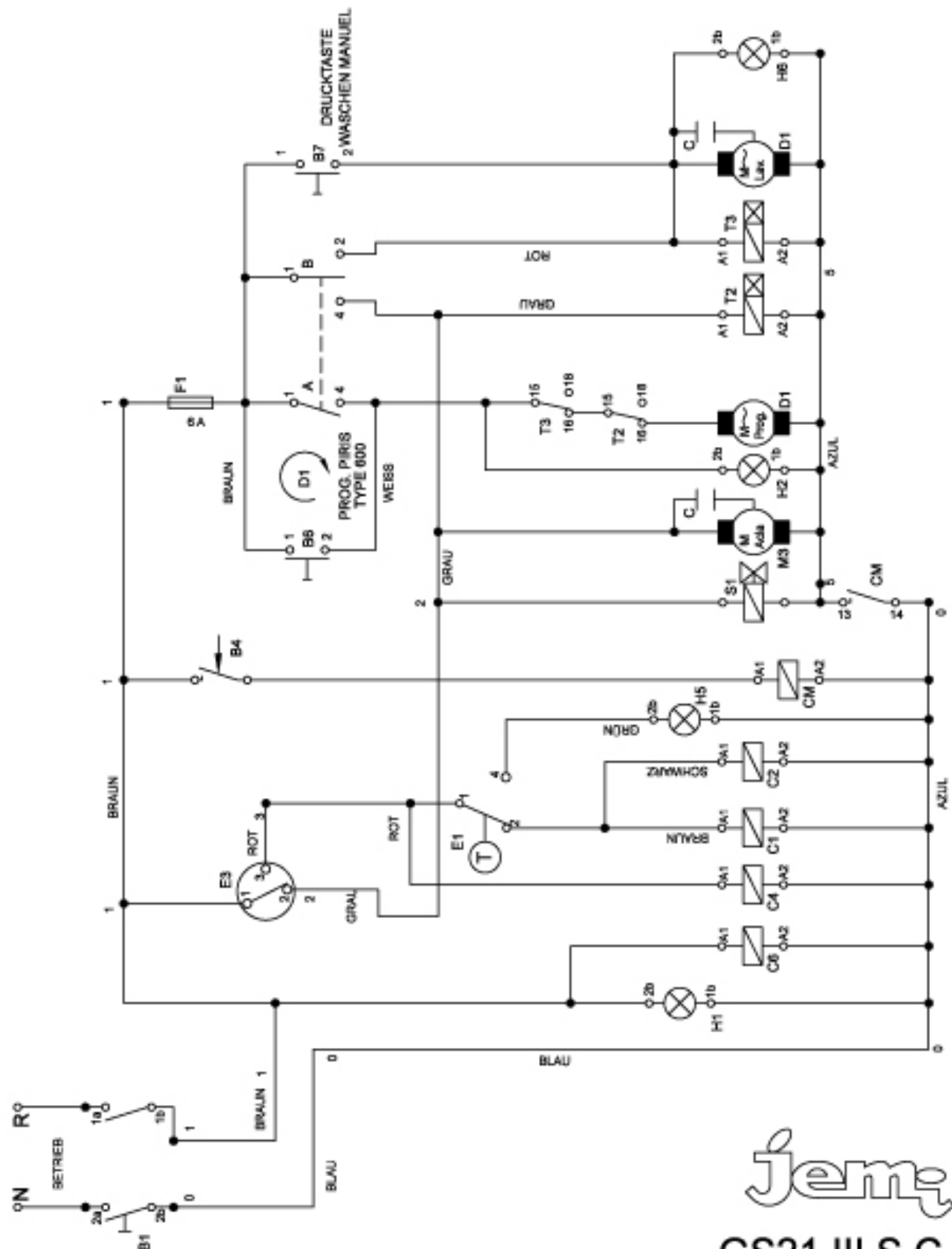

**Jem**  
GS21 III S.C.  
22/08/15

# ELEKTRISCHES SCHEMA GS-21 III OHNE BOILER

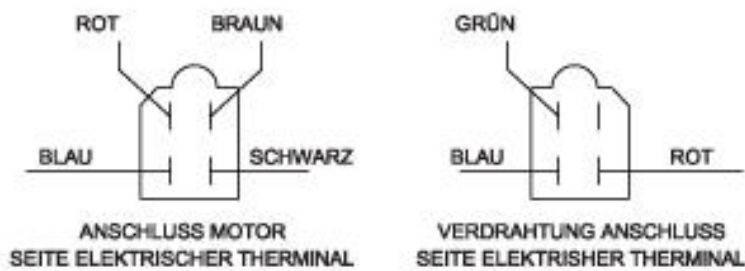
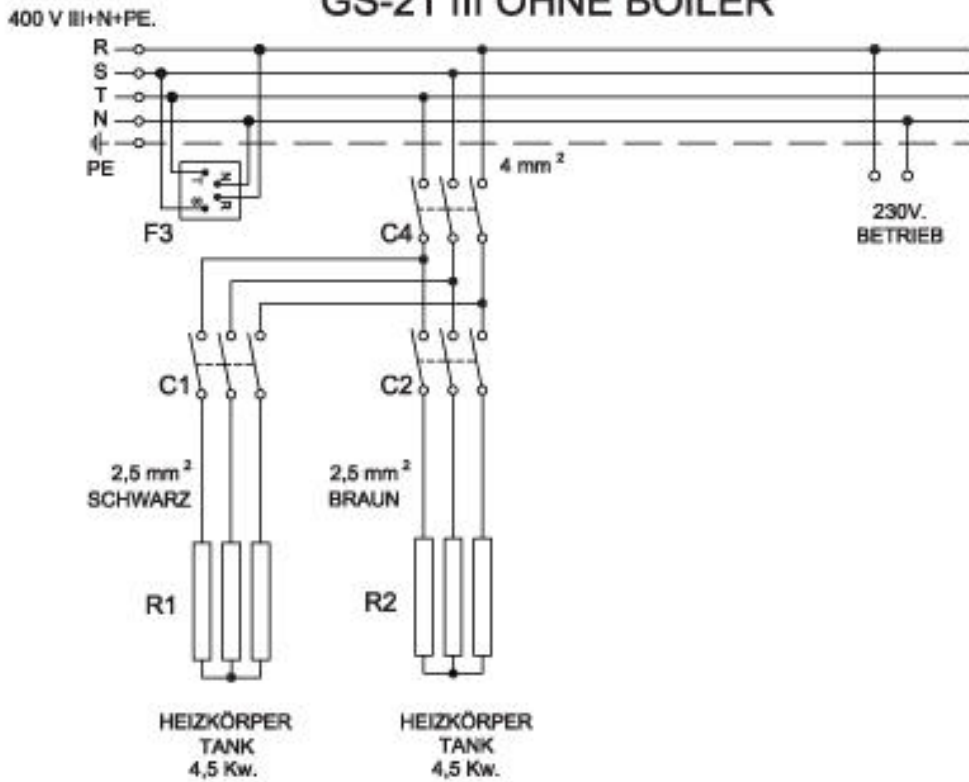

ANSCHLÜSSE  
OFFENER MOTOR  
1 HP

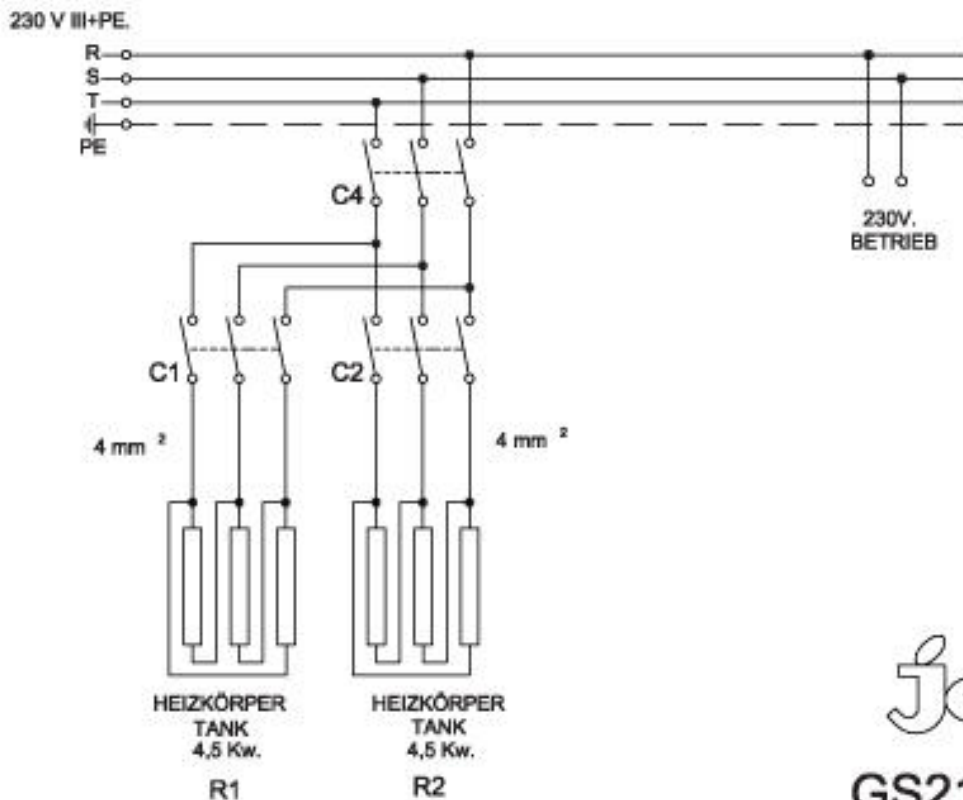

Jem

GS21 III S.C.

27/04/15

## ELEKTRISCHES SCHEMA MOD: GS-21 III OHNE BOILER

B1	SCHALTER INBETRIEBNAHME.
B4	MIKROTÜR.
B6	SCHALTER
C	MOTORKONDENSATOR.
C1	HEIZKÖRPERSCHÜTZ BOILER.
C2	HEIZKÖRPERSCHÜTZ TANK.
C4	SCHÜTZ HEIZUNG.
CM	RELAIS MIKROTÜR.
D1	PROGRAMMSCHALTER.
E2	THERMOSTAT TEMPERATURERREGLER TANK.
E3	NIVEAUDRUCKREGLER.
F1	SICHERUNG.
F3	FILTER ANTIPARASITENKONDENSATOR.
H1	ANZEIGER INBETRIEBNAHME.
H2	ANZEIGER SPÜLPROGRAMM.
H5	ANZEIGER RICHTIGE TEMPERATUREN.
M1	SPÜLMOTOR.
M3	MOTOR NACHSPÜLPUMPE (OPTION).
R1	HEIZKÖRPER BOILER.
R2	HEIZKÖRPER TANK.
SI	ELEKTROVENTIL FULLEN / NACHSPÜLUNG
T2	PROGRAMMSCHALTER NACHSPÜLUNG
T3	PROGRAMMSCHALTER WASCHEN

EDITION 27/04/15

## Technical data:

Hourly output about 190 bottles/h  
Rinsing time: 6 min 30 sec.

Pump capacity: 736 W  
Circulation rate: 330 l / min.  
Tank heater: 2 x 4500 W  
Overall connected load: 9736 W  
Voltage: 400 volts

Tank contents: 29 l  
Water consumption/Rinsing process: about 7.8 l  
Water pressure: 2.5 bars  
Connections/Supply and drain  $\frac{3}{4}$ " 50 mm Ø

Rack height: Bottles of up to 380 mm  
Basket dimensions: 500 x 500 mm  
Equipment of baskets: 1 bottle basket  
1 crate carrier for bottle crates

Dimensions:  
Width: 580 mm  
Depth: 630 mm  
Height incl. feet: 820 mm

# Bottle Basket

The system of our bottle basket is suitable for almost all types of bottles. No matter if you need to rinse NRW-, long necked, NF- or flip top bottles.

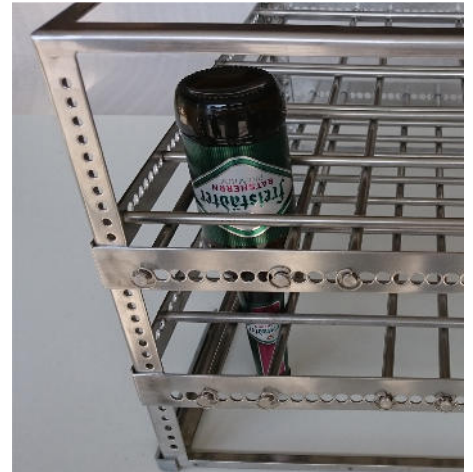

Scope of delivery:



- 1 pc basic basket
- 8 pcs support rails
- 32 pcs locknuts + reserve
- 36 pcs support rails
- 72 pcs clips + reserve

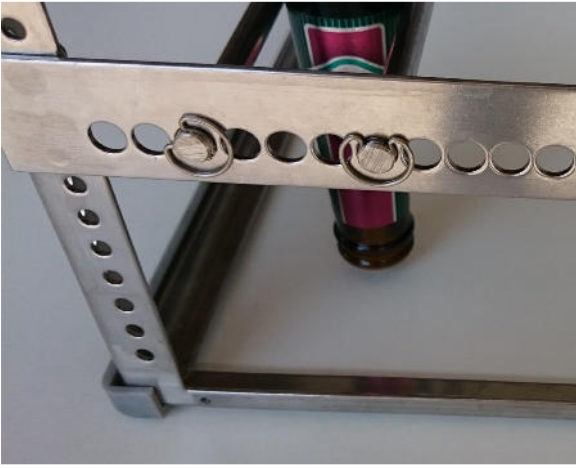

First check, at which height the bottom support rail shall retain your bottle. At this, make sure that the bottle opening should only be 30-35 mm above the bottom.



The following distances of the support rails are suitable for almost all bottles:  
View of the basket from the front: From the left to the right:  
2 holes free – rod – 3 holes free – rod – 7 holes free – rod – 3 holes free – rod – 8 holes free – rod – 3 holes free – rod – 7 holes free – rod – 3 holes free – rod – 2 holes free.



Lateral view of the basket from the left: From the left to the right:  
1 hole free – rod – 3 holes free – rod – 4 holes free – rod – 3 holes free – rod – 4 holes free – rod – 3 holes free – rod – 3 holes free – rod – 3 holes free – rod – 4 holes free – rod – 3 holes free – rod – 5 holes free.

After having determined the height of the seats for the bottles by means of the supporting bars fix the support rails on the base frame.

The holes are drilled in the support rails from the centring. Therefore, the holes to the bottom for the front and rear support rail, and the holes towards the top for the lateral support rail.

Fix the support rails by means of the locknuts.

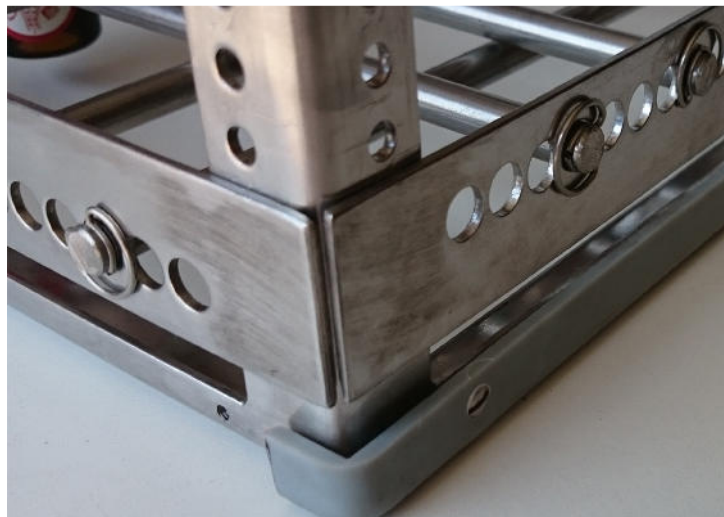

Insert the support rails through the holes. Start with the support rails from the front to the rear.

Fix the support rails with the clips included in the delivery.

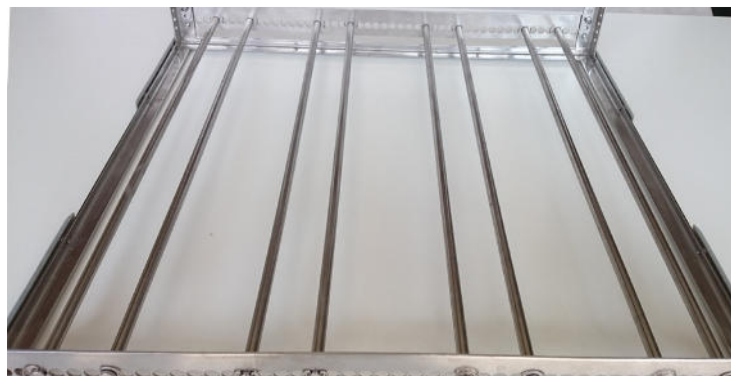

Then insert the supporting bars for the lateral support rails. Also fix them by means of clips.

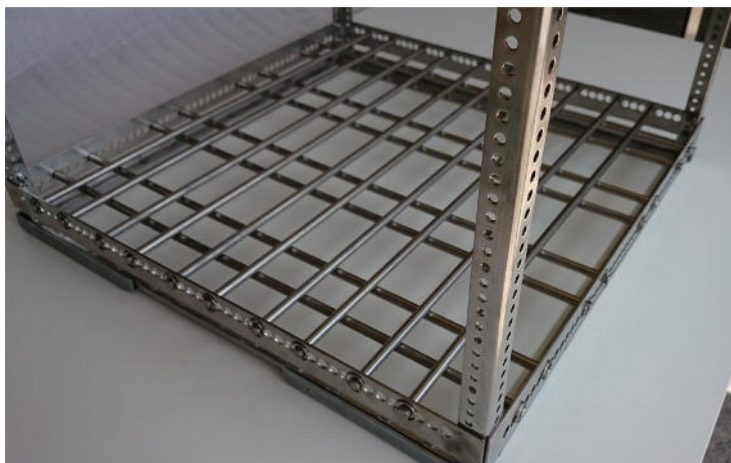

Perform the same process for the top support rail.  
Please note, that the bottles are as vertical as possible in the position.



Please observe that the top support rails are not at the same height as the labels of the bottle.

The labels should be collected on the support filter when they are detached from the bottle.

**Important note:**  
The basket must always be oriented in the same direction into the machine. Therefore, the frame was marked with our logo at one position.



Have fun when rinsing your bottles.



Please proceed as follows in order to check if the fresh water nozzles exactly spray into the bottle:

Switch off the machine and remove the overflow pipe.  
Seal the "drive nozzle" (on the right) at the top re-rinsing arm and fix the arm.



Place the bottle basket with 4 bottles in the first row. Place the basket into the machine. Take a magnet and guide it to the right of the panel. The magnetic door switch is behind the panel.



As soon as the door switch is activated, the water will spray out of the nozzles. If one or several nozzles do not spray into the bottle, you may twist the rinsing arms a bit in order to place them into the correct position.

